

GALLONS	56	53	59	56
LITERS	212	201	222	210
	TOTAL CAPACITY	USEABLE CAPACITY	TOTAL CAPACITY	USEABLE CAPACITY
	DIESEL FUEL		BIO-DIESEL/ HYDRAULIC/WATER	

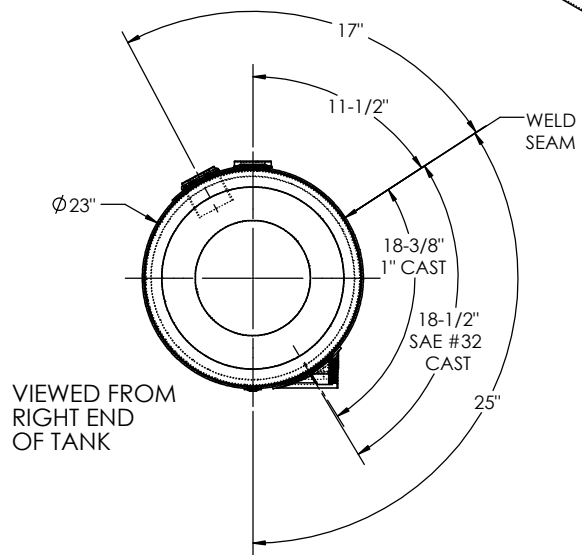
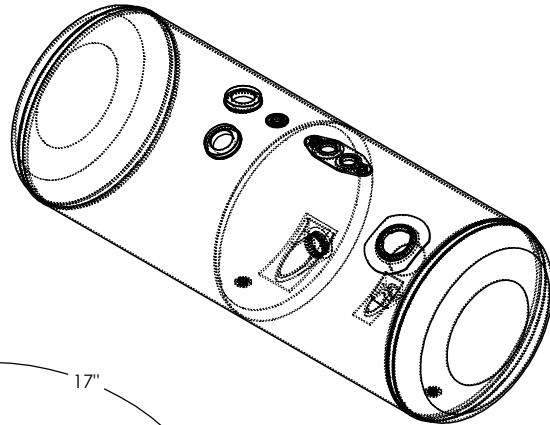
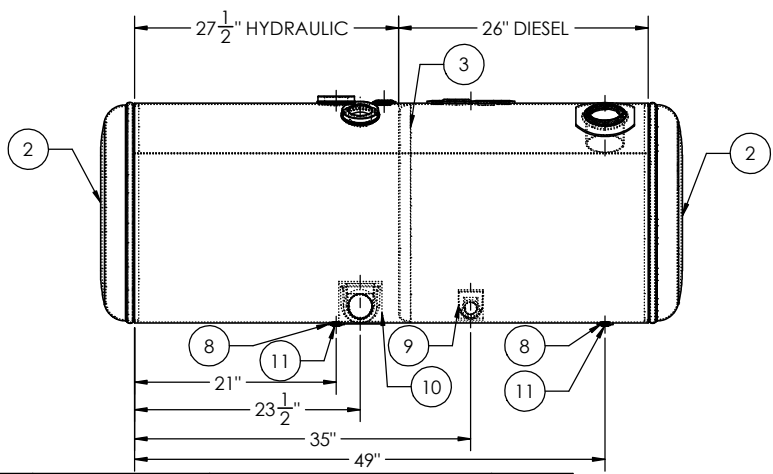
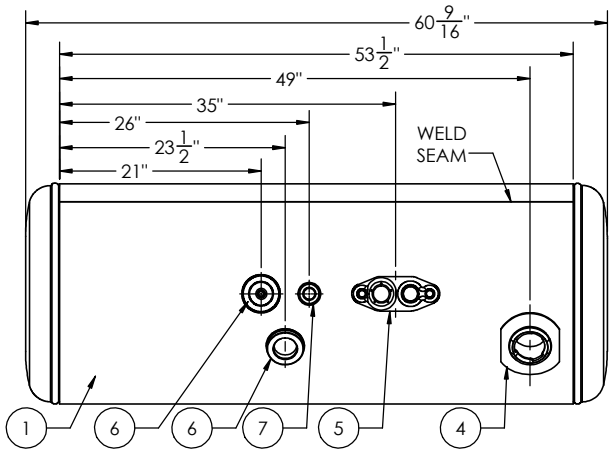

ITEM NO.	PART NUMBER	DESCRIPTION	QTY.
1	BRL-AT-PB-1096	1/8" TANK BARREL	1
2	ECP-3680012200	23" MILGRADE ALUMINUM PETERBILT STYLE END CAP	2
3	BHD-368001220	23" MILGRADE ALUMINUM BULKHEAD	1
4	FLN-110022200	MILGRADE ALUMINUM PETERBILT FILL NECK	1
5	ADP-1132210	MILGRADE ALUMINUM PETERBILT ADAPTER PLATE	1
6	FLG-00282221	SAE #32 MILGRADE ALUMINUM FLANGE TYPE 1	2
7	FLG-070220	1" NPTF MILGRADE ALUMINUM FLANGE	1
8	FLG-040220	3/8" NPTF MILGRADE ALUMINUM FLANGE	2
9	COC-70210	1" NPTF CAST ALUMINUM CASTING	1
10	COC-0282210	SAE #32 CAST ALUMINUM CASTING	1
11	94134	3/8" NPTF STEEL SOCKET HEAD PIPE PLUG 3/4" TAPER DRYSEAL	2

PETERBILT PART NUMBER: 11-04706-045F045H

TITLE: 23" D x 53.5" L		UNLESS OTHERWISE SPECIFIED:		NAME	DATE
SIZE C	REV	QC	INITIALS	DRAWN	
		PSI		CHECKED	
		DIMS		ENG APPR.	
		PARTS		MFG APPR.	
TAG		Q.A.		COMMENTS:	
PKG		MATERIAL: 5052 H32 ALUMINUM	FINISH: SEE BOM	11317 N. US HWY 14 800-452-6630 HARVARD, IL 60033 FAX 855-774-6918 815-943-6649 WWW.ALUMITANK.COM INFO@ALUMITANK.COM	
DO NOT SCALE DRAWING				DWG. NO. AT-PB-1096 REV. A SCALE: 1:10 WEIGHT: 70.89 SHEET 2 OF 2	